



Optical Transport Network of the ADRENALINE Testbed: GMPLS Metropolitan All-Optical Tuneable AWG-based R-OADM ring

R. Muñoz, P. Vázquez, I. Martínez, M. Requena, C. Pinart, G. Junyent

Publication:	in Proc. IEEE Create-net International Conference on Testbeds and Research Infrastructures for the Development of Networks and Communities (TRIDENTCOM 2006)
Vol.:	-
pp.:	-
No.:	-
Date:	Barcelona (Spain). March 1-3 2006

This publication has been included here just to facilitate downloads to those people asking for personal use copies. This material may be published at copyrighted journals or conference proceedings, so personal use of the download is required. In particular, publications from IEEE have to be downloaded according to the following IEEE note:

©2007 IEEE. Personal use of this material is permitted. However, permission to reprint/republish this material for advertising or promotional purposes or for creating new collective works for resale or redistribution to servers or lists, or to reuse any copyrighted component of this work in other works must be obtained from the IEEE.

Optical Transport Network of the ADRENALINE Testbed: GMPLS Metropolitan All-Optical Tuneable AWG-based R-OADM ring

Raül Muñoz, Patricia Vázquez, Ivan Martínez, Manuel Requena, Carolina Pinart and Gabriel Junyent
Centre Tecnològic de Telecomunicacions de Catalunya (CTTC)
Parc Mediterrani de la Tencologia, Av. Canal Olímpic s/n 08860 Castelldefels, Spain.
{raul.munoz, patricia.vazquez, ivan.martinez, manuel.requena, carolina.pinart, gabriel.junyent}@cttc.es

Abstract

Given the abundance and strategic importance of ring fiber-plants in metropolitan area networks, and the accelerating growth of Internet traffic, it is crucial to make use of recent advances in optical networking technologies such as WDM, ROADMs, OXCs and tuneable transceivers in order to offer the most cost-efficient traffic transport. The objective of this paper is to present the metropolitan all-optical tuneable AWG-based R-OADM ring network implemented in the ADRENALINE testbed.

1. Introduction

The rapid growth of data traffic is undeniable thanks to the Internet explosion. The emergence of the Internet is well measured by the proportion of data traffic to voice traffic on networks. Currently the voice traffic continues its traditional *lethargic* growth pattern, while Internet traffic continues an inexorable exponential growth. Specifically voice traffic grows by 6 - 9 %/year, whereas internet traffic is doubling every four months. Based on current levels of growth, the entire voice traffic may amount to less than one percent of the total before 2008 [1]. Therefore the need to carry more traffic, combined with the need to minimize the cost of carrying this traffic, results in a situation where *Service Providers* (SP) need solutions that enable them to carry large volumes of traffic in the most cost-efficient manner.

Built to reliably and efficiently transport voice traffic, the statically configured *Synchronous Optical Network/ Synchronous Digital Hierarchy* (SONET/SDH) metro network is not optimized for demands of increased bandwidth and dynamic services, given the inherently bursty nature of *Internet Protocol* (IP) data traffic and the fixed-bandwidth pipes of *Time Division Multiplexing* (TDM) transport [2]. Most of current SONET (SDH) metropolitan area networks

are based upon fiber-ring architectures. Given this large, entrenched base of ring topologies, one possible solution is to plan for a migration to equivalent dynamic optical ring architectures based upon recent advances in optical networking technologies [3] such as *Wavelength Division Multiplexing* (WDM), *Reconfigurable Optical Add Drop Multiplexers* (ROADMs), programmable *Optical Cross Connects* (OXCs) and tuneable transceivers, capable of providing reconfigurable high-bandwidth end-to-end optical connections. It allows optical transport networks to be automatically manageable, in contrast to the current statically configured transport networks. R-OADMs can significantly reduce the cost of metro WDM ring networks by allowing traffic to bypass intermediate nodes without expensive *Optical-Electro-Optical* (O-E-O) conversion, saving *Capital Expenditure*(CapEx) and *Operational Expenditure* (Opex)

The objective of this paper is to present the implemented metropolitan all-optical tuneable AWG-based R-OADM ring network of the ADRENALINE testbed¹. The ADRENALINE is an intelligent optical transport platform that combines both real and emulated optical nodes and links based on a distributed *Generalized Multiprotocol Label Switching* GMPLS-based control plane and a distributed management plane combining the industry standard *Simple Network Management Protocol* (SNMP) with user-friendly *eXtensible Markup Language* XML based tools. The remainder of this paper is organized as follows. A general overview of the main R-OADMs ring topologies employed in the ADRENALINE testbed is described in section 2. In section 3 we give insight of the main control and management concepts implemented in the ADRENALINE testbed. Section 4 depicts the general architecture of the ADRENALINE's transport network. After that we present the implemented tuneable AWG-based R-OADM node, fo-

¹ This work is part of the CTTC strategic NetCat project

cusing on the architecture in section 5, on the control in section 6 and finally on the monitoring in section 7. Section 8 concludes the paper.

2. R-OADMs ring topologies

In general, metro DWDM transport networks are built as ring topologies. These rings can be divided into unidirectional and bidirectional signal flows [3]. In unidirectional rings (*Dedicated protection Ring*, DPRings), one fiber is dedicated as working fiber and the other fiber is dedicated as protection fiber. Working and protection fibers operate in opposite directions, that is the working ring operates on the clockwise direction and the protection ring on the counter clockwise direction. In bidirectional rings *Shared Protection Ring*, SPRings), both fibers are dedicated as working and protection fiber, that is, the working channels in one fiber are protected by the protection channels in the other fiber, travelling in the opposite direction around the ring. In DPRings an available resource is dedicated to protect a single working lightpath. In SPRings the same available resource may be used to provide protection to multiple working lightpaths. For both DPRing and SPRing, two possible implementations exist, depending whether the protection occurs on the *Optical Channel* (OCh) or *Multiplex Section* (OMS) level.

2.1. OCh Dedicated protection

OCh dedicated protection comprises 1+1 and 1:1 protection. Both cases require the provisioning of two dedicated optical connections, one for the working lightpath (provisioned using the working fiber) and the other one for the protecting lightpath (provisioned in the protecting fiber). In 1+1 protection, the source client signal is split and transmitted simultaneously on the working and protection lightpaths. The destination is responsible for monitoring the working lightpath and dynamically switch over the protecting lightpath if the received working signal is degraded (e.g. *Loss of Signal* (LOS), *Loss of clock*, etc). In 1:1 protection, the protecting lightpath is used to transmit low priority traffic while there is no failure. Upon a degradation of the received working signal at the destination, both the source and destination nodes switch the transmitter and the receiver respectively over the working lightpath, disabling the transmission of low priority traffic. Note that in this case a signalling mechanism is required in order to allow the destination node to inform to the source node about the detected failure. A DPRing that uses OCh protection is referred to as *Optical Unidirectional Path Switched Ring* (OUPSR) or OCh-DPRing.

2.2. OMS Dedicated protection

In OMS switching, there is no provision of dedicated protecting lightpaths. Each R-OADM has a pair of switches for looping back the working fiber over the protecting fiber, that is, all the wavelengths transmitted in the working fiber are jointly switched. Upon a failure, the R-OADMs adjacent to the failure switch the affected working fiber on the protection fiber of the ring. Restoration of traffic is handled by the nodes at the ends of the failed link. A DPRing that uses OMS protection is referred to as *Optical Unidirectional Line Switched Ring* (OULSR) or OMS-DPRing.

2.3. OCh Shared protection

The OCh Shared protection does not require the dedicated establishment of protecting lightpaths in contrast with the OCh Dedicated protection. Therefore the same protecting lightpath can be used for several working lightpaths as long as they have the same wavelength as the protecting lightpath. For the OCh Shared protection, as well as for the OCh dedicated protection, the restoration of the traffic is handled by the source and the destination node. This pair of nodes switch the affected working lightpath to the opposite side of the ring over the protecting lightpath. A SPRing that uses OCh protection is referred to as *Optical Bidirectional Path Switched Ring* (OBPSR) or OCh-SPRING.

2.4. OMS Shared protection

The OMS Shared protection works in the same way as the OMS Dedicated, with the peculiarity that the set of wavelengths employed for working traffic in both directions around the ring must be different in order to avoid wavelength contention. One possible solution is to use the same set of wavelengths for the working traffic in one direction and the protection traffic in the opposite direction around the ring and viceversa. A SPRing that uses OMS protection is referred to as *Optical Bidirectional Line Switched Ring* (OBLSR) or OMS-SPRING.

3. Control and Management of the ADRENALINE testbed

The ADRENALINE testbed is a *GMPLS-based Intelligent Optical Network* (ION) developed at CTTC laboratories. The ADRENALINE testbed is focused on the research and development of a GMPLS-based distributed control plane (RSVP-TE Signaling for lightpath provisioning and OSPF-TE Routing for topology and optical resources dissemination) and a distributed management plane combining the industry standard Simple Network Management Protocol (SNMP) with user-friendly

XML based tools to allow users the dynamic provisioning of lightpaths. The ADRENALINE testbed comprises 9 Linux-based routers which emulate Optical Connection Controllers (OCC) for the GMPLS-based distributed control plane, and 3 Windows-based PCs which emulate the Distributed Optical Managers (DOM) for the management plane. Each OCC has been implemented on a Linux-based router with a Pentium IV 2,6 GHz processor. The *Data communication network* (DCN) employed for enabling communications between OCCs and DOMs is based on fast Ethernet point-to-point links carried over both emulated and real links. The real links are bidirectional optical fiber links with a distance of 35Km each (control channels are carried on 1310nm). The simulated links are based on an additional PC with a network emulation package that allows to emulate fixed and variable packet delays, packet losses, bandwidth limitations, etc., between two OCCs or DOMs. Therefore the topology of the DCN allows to be reconfigured following either a ring topology (both unidirectional and bidirectional) or a mesh network topology.

The design and implementation of the GMPLS-based control plane and the distributed management plane of the ADRENALINE testbed is out of the scope of this paper. For more information about architecture refer to [4], and for more information about research on control and management refer to [5][6].

4. Optical Transport Network of the Adrenaline Testbed

The main functions of the ADRENALINE's all-optical transport network are the provision of reconfigurable (space and frequency) end-to-end optical channels, transparent to the format and payload of client signals (e.g SDH, Ethernet, etc), and the monitoring about the state of optical connections and their performance, such as errors or signal quality. The ADRENALINE's optical network is being built in two phases. In the first phase (figure 1 of the ADRENALINE testbed, the transport plane is composed by a DWDM ring with three tuneable AWG-based R-OADM's that can work as a unidirectional ring or as a bidirectional ring, supporting both OCh and OMS protection. Each pair of optical nodes are connected using two optical fiber bobbins of 35 Km. each one, resulting a total of 210 km. There are a total of 8 DWDM transceivers up to 2,5 Gb/s, 6 of them have fully tuneable laser sources, and the rest works on two fix wavelength. Modulating the optical channels is achieved by using 2.5 Gbit/s direct modulation.

In the second phase (fig. 2, one R-OADM will be upgraded to *Optical Cross-Connect*(OXC), allowing to route wavelengths between different fibers, and a new fourth OXC-based node will be added, in order to allow to mi-

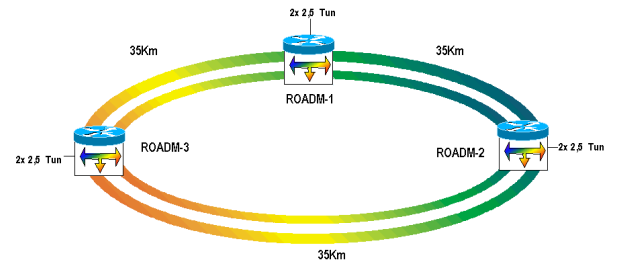

Figure 1. The ADRENALINE Testbed phase 1

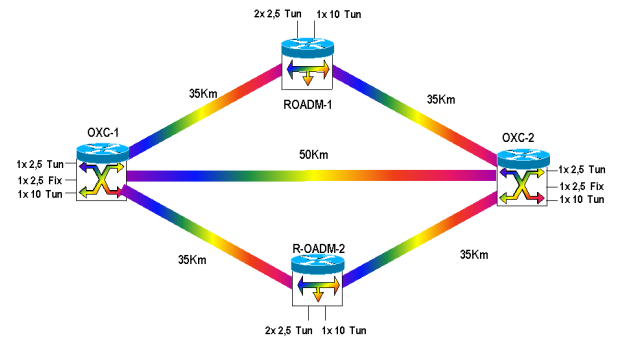

Figure 2. The ADRENALINE Testbed phase 2

grate from ring to mesh topology. Four new 10Gb/s tuneable transceivers will be introduced, one for each node, with the use of Lithium Niobate external optical modulators. Currently all efforts are focus on phase I, therefore this paper will concentrate on research, development and implementation issues of the ADRENALINE's R-OADM node.

5. ADRENALINE's R-OADM node

The current R-OADM's, entirely designed and developed at CTTC Laboratories, have the structure shown in Figure 4. Each R-OADM is performed by a two-stage unit. The add/drop stage (first stage) filters the drop channels out of the DWDM signal and adds new channels into the ring. The distribution stage (second stage) assigns the added and dropped signals to the tributary interface cards of the client equipment. Figure 3 shows a laboratory view of the R-OADM node of the ADRENALINE testbed

5.1. Add-Drop Stage

In the ADRENALINE testbed, the add/drop stage implemented by the CTTC's engineering unit is based on a two array of nine 2x2 reconfigurable optical switches in combination with a single 18x18 *Array Wavelength Grating*(AWG). This equipment also incorporates a controller

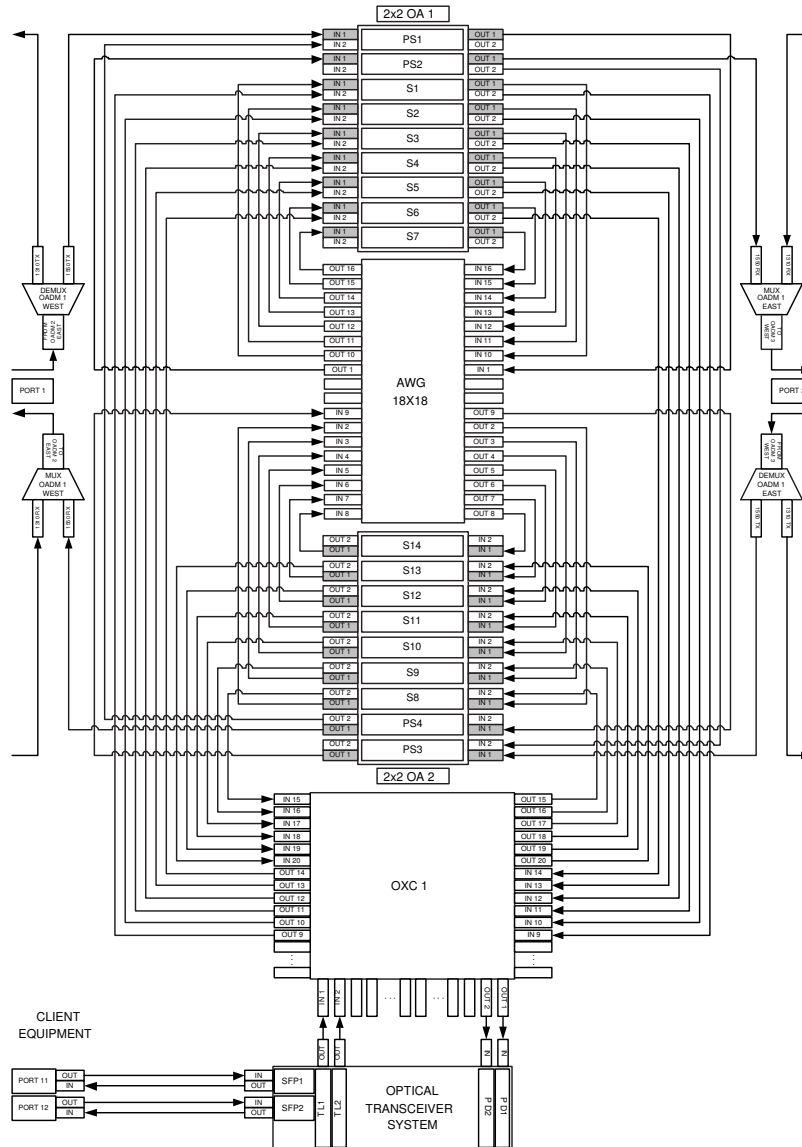

Figure 4. R-OADM architecture

card reachable via Ethernet to allow the configuration of the two 2x2 arrays.

5.1.1. Array Wavelength Grating (AWG) Card The AWG is a passive WDM device which can be used as a multiplexer, demultiplexer, a drop-and-insert element, or a wavelength router. In general AWG consists of M input and M output slab waveguides and two identical focusing planar star couplers connected by M dispersive waveguide array. An important property of the AWG is the free spectral range (FSR), also known as the demultiplexer periodicity. The free spectral range denotes the wavelength and frequency spacing between the maxima of the the interference pattern because of the periodicity characteristic

of the AWG. For the three 18X18 AWGs specifically designed for the ADRENALINE testbed, since this kind of equipment is not available commercially, the FSR comprises 18 wavelengths, from ITU frequency 192.10THz to 193.8THz spaced 100GHz. This property allows that wavelengths can be reused if the input ports are different, that is, we use a single AWG for multiplexing and demultiplexing the same wavelengths but using different ports, as shown in figure 5. Note that the ADRENALINE testbed employs 7 wavelengths, from 193.0THz (1553.33nm) to 193,6THz (1548.51nm). Figure6.a shows the implemented AWG card.

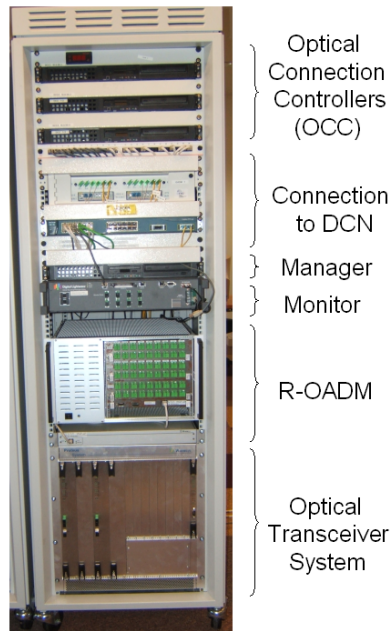

Figure 3. Laboratory view of the ADRENALINE's R-OADM node

5.1.2. Array of 2x2 optical switches Card As shown in figure 4, the implemented R-OADM needs of two 2x2 optical switches card. Each of these cards holds nine 2x2, add/drop optical fiber switches, whose configuration is handled by a controller card that will be described in section 5.1.3. The optical switches are provided with some electric contacts by which their state (cross/bar) can be driven, and some other contacts allow the readout of the present switch position. The switches are latched-type, which means that the device remains in its latest position following an undesired power loss. A *Complex Programmable Logic Devices* CPLD placed on each of these boards acts as the bridge interpreter between the controller card and the array of switches, setting them according to the commands received from the former. It reduces the microcontroller load and offers switches state information constantly update. The CPLD is reprogrammable via a *Joint Test Action Group* JTAG header that is sited on the board.

A customized serial port physically supports communications between these boards. The two 2x2 optical switches cards share such serial port, and thus a careful arbitration must be laid in order to avoid any potential conflict. In regards of this fact and the possibility of future additional switches cards, each of them is identified with a particular address that is set manually with their respective address switch. Figure 6.b shows the implemented array of 2x2 optical switches card.

Channel	Frequency (THz)	Wavelength (nm)
30	193.0	1553.33
31	193.1	1552.52
32	193.2	1551.72
33	193.3	1550.92
34	193.4	1550.12
35	193.5	1549.32
36	193.6	1548.51

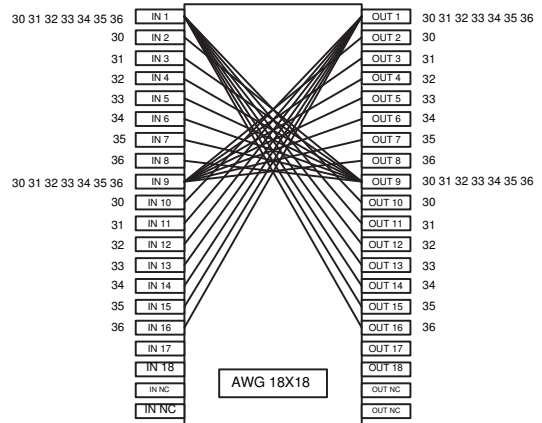

Figure 5. AWG architecture

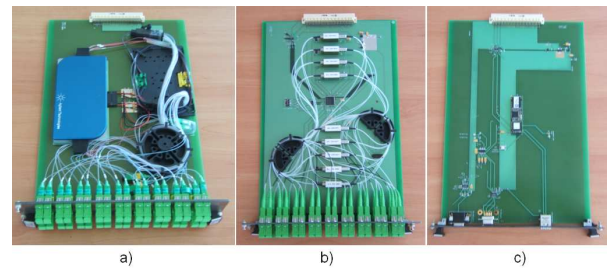

Figure 6. View of the implemented R-OADM's card

5.1.3. Controller Card For each R-OADM, its arrays of 2x2 optical switches are managed by the controller card, which integrates a micro controller 32-bit ARM7TDMI. Such micro controller is uClinux based, and is connected to the rest of the system through an Ethernet plug, although other channels are available on the card: standard serial port and current latch (RS-422). The micro controller is reprogrammable through any of these mentioned channels. Another customized serial port communicates with the CPLD on each of the two switches boards, trafficking commands to set or read the switches states. Both the arrays of switches and the controller card can be reset either via hardware (with a switch provided with the controller card) or software, thus allowing synchronization at the start-up of all

the cards of the system.

The ARM7TDMI 32-bit processor, named *Optical Switching Module Controller (OSMC)*, is a 55 MHz CPU and its functions are to configure, to supervise and to control the Add-Drop Stage, that is, to verify and to modify the status of the 2x2 optical switches (cross/bar). The OSMC uses 2 different communication protocols. The communication protocol with the arrays of 2x2 optical switches is a RS-232 protocol, while the communication with the control plane of the ADRENALINE testbed (R-OADM Controller, section 6) is property, implemented via Ethernet. When the OSMC starts up, it opens the communication channels and then it tries to configure all optical switches of the Add-Drop Stage. If the operations are completed successfully, the OSMC informs to the control plane (R-OADM controller) that it is ready to receive its requests. There are two possible requests coming from the control plane. The first one is to monitor the status of the optical switches. The second one is configuration of the optical switches. If the OSMC receives a status monitor request, it verifies the last status of the 2 optical arrays, and then it returns the physical status of each 2x2 optical switch. So the control plane check the status of all optical switches at the same time. However, the performance of the status configuration request is a little bit different, since the control plane can change the status of any status 2x2 optical switch separately, although the OSMC will return the status of the 2 arrays of 2x2 optical switches. The time spent to perform every request is 15 ms. approximately, therefore it is a fast optical commutation system for wavelength-routed networks. When the OSMC does not receive requests from the control plane, it monitors periodically (every 20 ms.) the status of the 2 optical arrays in order to supervise the system, since in this way it can report to the control plane of any irregular event happened in the Add-Drop Stage. The OSMC has also a *user interface (UI)* via Ethernet, which indicates the current status of all the system. Figure6.c shows the implemented controller card.

5.1.4. Add-Drop Stage operation The add/drop stage has been implemented in such a way that can work as a unidirectional ring or bidirectional ring via software configuration. An incoming signal (in figure 7 port 1) composed by control (1310nm) and WDM data (1550nm) signal is demultiplexed using a second/third window multiplexor. Then the WDM data signal enters to the 2x2 OMS protection switch (PS1 in the figure) of the first array of 2x2 optical switches. If this switch is in pass-through, the WDM signal is demultiplexed by the AWG into separate wavelengths. Then each wavelength enters again to the array of 2x2 optical switches (from S1 to S7). The same process apply for the incoming signal from port 2, but in this case using the second array of 2x2 optical switches (S9 to 14). These

switches are capable of dropping the wavelength, adding a new one, or passing-through the wavelength. Each one of the seven wavelength has its own switch, so all the wavelengths that cross the node can be added or dropped. Added or dropped wavelengths are connected to the distribution stage explained in section 5.2.

In the general case, all the 2x2 optical switches from both arrays can be used for adding or dropping purposes, except when the OMS protection is required. If the node is configured as OMS unidirectional, all the switches located in the second 2x2 array are disabled for adding or dropping purposes, and are configured as pass-through. For a OMS bidirectional configuration, each array of 2x2 optical switches must use a different set of wavelengths in order to avoid wavelength contention when the traffic of one fiber is switched over the other fiber. Therefore only the half of the 2x2 switches in each array can be used for adding or dropping purposes, and the rest must be configured as pass-through.

Finally, each output wavelength from the 2x2 array is wavelength-multiplexed by the AWG before the signal is sent to the output OMS protection switch (PS2). If this protection switch is in pass-through, the WDM signal is multiplexed with the control signal coming from the OCC and transmitted to the output fiber (port 2). If the OMS protection is activated (figure 8), the protection switches (PS2 and PS3) are in cross, and the WDM data signal is inserted again in the AWG, wavelength-demultiplexed, passing-through the 2x2 optical switches and wavelength-multiplexed. Last, the WDM signal arrives to the protection switch (PS4) in pass-through and transmit the signal to the output fiber (Port 1). The total insertion losses introduced by the implemented R-OADM for a pass-through are around 24,74 db, and for a pass-through in protection are 43,37. This high losses are due to the AWG, that introduces around 10dB every time that it is crossed. Therefore the R-OADMs requires an optical amplifier system to compensate this signal attenuation. Currently the ADRENALINE testbed is in phase of studying the best solution of optical amplification.

5.2. Distribution Stage

The distribution stage between the added/dropped wavelengths and DWDM transceivers is realized using two 32x32 all-optical OXC, based on MEMS technology, which can be virtually divided in order to have smaller and independent optical switches. The client tributary cards (PoS, GigE, etc) are connected to the DWDM transceivers, transmitting optically at 1310nm. This distribution stage allows to connect any added or dropped wavelengths with any client tributary card.

5.2.1. Optical Cross-Connect, OXC The Micro-Electro Mechanical Switching (MEMS) technology is one of the

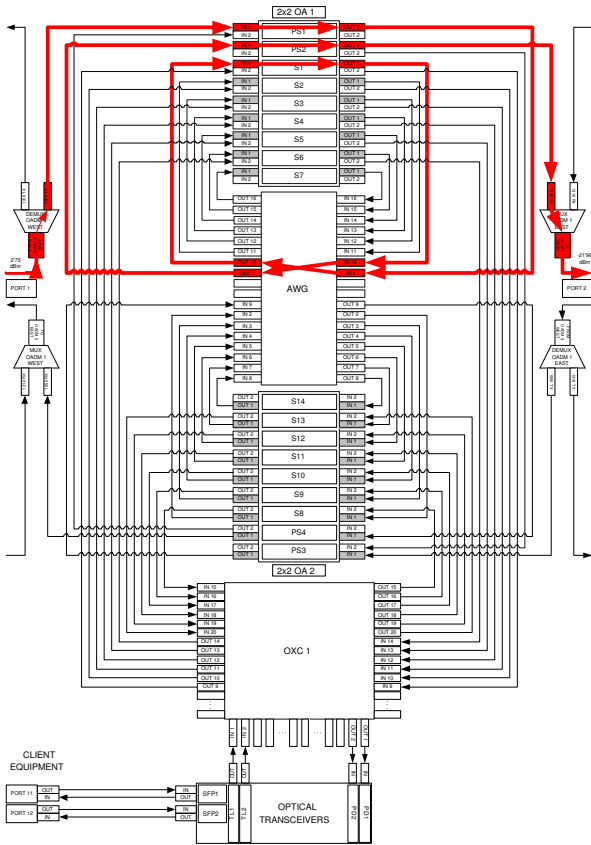

Figure 7. Example of Pass-through of channel 30 from port 1 to port 2

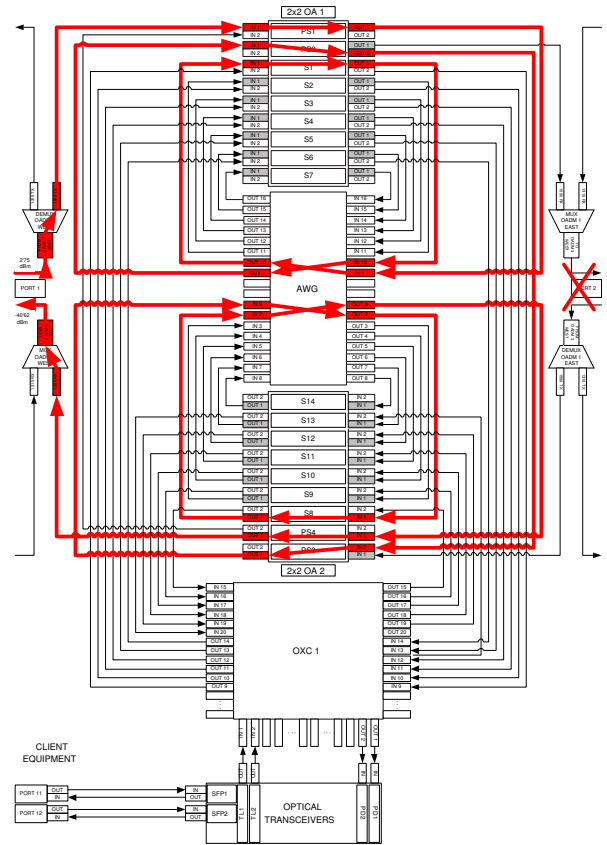

Figure 8. Example of Pass-through in protection of channel 30 from port 1

key enablers of all-optical switching for photonic networks. Optical MEMS integrates 2D or 3D arrays of tilting mirrors that steer the light, or reflective strips are raised and lowered to attenuate the signal, onto a silicon chip. The main advantages of the MEMS technology are its ability to create all-optical components, its fast response time (tens of microseconds), and its long-term repeatability. In the ADRENALINE testbed, the MEMS-based OXC's direct optical signals from input to output ports by flat mirrors, approximately 1mm in diameter, which can be tipped up to two orthogonal axes by generation of an electrostatic force. The controls that generate the force use a closed-loop feedback system on every connection to monitor and correct alignment, ensuring reliable, accurate switching. The ADRENALINE's OXC's are symmetrical configurations of non-blocking MEMS switches, with a built-in fiber patch panel of 32x32 ports, an average switching delay of 25ms, and very low insertion loss ($2\text{dB} \pm 1\text{dB}$). The OXC's integrate variable optical attenuators (VOA) that can be used to equalize optical signals, and can be partitioned virtually to create smaller symmet-

rical configurations, such as 8x8 or 16x16. The basic function of the OXC's is the interconnection of an input port with an output port. In the future, replication of a single optical transmission to multiple receivers will be integrated, to enable multicast and protection schemes. As for interfaces, the OXC's are enabled with a Transaction Language One (TL1) engine, which supports up to eight TL1 sessions. The TL1 interface serves two purposes; remote configuration and alarm management. Configuration of input-output pairs can be done one by one ($\langle in_x, out_y \rangle$) or in arrays ($\langle in_{x_1}, \dots, in_{x_N}, out_{y_1}, \dots, out_{y_N} \rangle$), to optimize the delays of setting up and tearing down optical connections. VOA levels can be specified in this operation, or separately. Finally, alarms of the status of the OXC's, and the power levels of its input and output ports, can be polled or obtained asynchronously (autonomous alarms).

5.2.2. Optical transceiver system The optical transceiver system is composed by a master card and 3 DWDM transceivers up to 2,5 Gb/s (There is one optical transceivers for each optical node). Although these 3 DWDM transceivers

are similar, only 2 of them have a tunable laser source. The third DWDM transceiver works on a fix wavelength. However, the performance of the 3 DWDM transceivers is the same. Each DWDM transceiver has three different optical devices: one *Small Form-factor Pluggable* 1310nm SFP transceiver, one DWDM laser source and one DWDM photoreceptor. Each 1310nm SFP transceiver is connected bidirectionally to the client equipments (section 5.2.3). The 1310nm SFP transceiver acts as a *optical/electrical* (OE) and an *electrical/optical* /E/O) convertor up to 2,5 Gb/s. The incoming optical signal from the client equipment, carried at 1310nm , is photoreceived and converted to the electrical domain. This electrical signal is inserted to the DWDM laser source to modulate directly the optical channels. Tunable lasers has an operating range of 35nm (1528-1563 nm) allowing to tune 90 ITU channels at 50 GHz spacing. In the same way, the received DWDM channel from the distribution stage is converted to the electrical domain using the DWDM photoreceptor (up to 2,5 Gb/s), and then, the 1310nm SFP transceiver modulates this electrical signal, that is transmitted optically at 1310nm to the attached client equipment.

The optical transceiver system is controlled by the master card. This master card supervises the 3 DWDM transceivers and it is connected to the *Optical Transceiver System Controller* (OTSC) via RS-232. The OTSC has the same type of processor used in the controller card of the Add-Drop Stage (ARM7TDMI 32-bit with 55 MHz Linux-based CPU). The OTSC works in a similar way to the OSMC, that is, it configures the optical transceiver system, then it monitors the system and finally it performs the control plane requests (received via Ethernet)to the R-OADM controller. There are two main requests coming from the control plane. The first one is to switch on the DWDM laser source, specifying a the wavelength to tune. The second one is to switch off the laser source. In both requests, the OTSC returns to the control plane an acknowledge response. Finally, if the master card of the DWDM optical transceiver system detects any anomaly, the OTSC is immediately informed and it automatically reports the event to the control plane. As in the OSMC, the OTSC has also a *user interface* (UI) via Ethernet, where it is indicated the current status of the DWDM transceiver system.

5.2.3. Client Equipment Client equipments are emulated through a broadband tester that generates and analyzes IP traffic over *Gigabit Ethernet* (GigE) and *Packet over Sonet* (POS). This equipment counts with 8 GigE ports and 2 POS ports. Moreover the Broadband Tester has been programmed (tcl/tk script) in order to generate *User Network Interface* (UNI) optical connection requests to the optical network according to Poisson statistics, and holding times distributed exponentially. The traffic demand matrix between the UNI-emulated clients can follow both a uniform

(the traffic is uniformly distributed among all client pairs) and a non-uniform scheme (the traffic among all client pairs depends on "popularity"). The Broadband Tester has also been programmed to switch on the corresponding client laser (and generate and perform analysis of the IP packets) once a successful response from the optical network has been received through the UNI interface.

5.2.4. Distribution Stage Operation The distribution stage works in a similar way for added or dropped wavelengths. Let's consider the example of figure 9 in which the wavelength 30 is added and transmitted to port 2. The optical transceiver has its transmitter and receiver connected to some specific ports of the OXC, as well as the add/drop 2x2 optical switches. Then the OXC is used to connect optically the transmitter or receiver with the corresponding 2x2 optical switch in function of the wavelength and the output port requested. Following with the example, the transmitter is switched over the S1 optical switch (note that we are adding wavelength 30). This switch must be in the cross state in order to allow the incoming signal form the OXC to leave to the AWG. At the same time, the dropped wavelength is connected to the OXC when the switch is in cross. After that, the added wavelength is multiplexed by the AWG before the signal is sent to the OMS protection switch PS2. If the output port does not have any failure, the DWDM signal passes-through and leaves the R-OADM by the port 2.

If the port 2 is failed (figure 10), then the OMS protection switches PS2 and PS3 are in cross state, sending the signal to the AWG that is wavelength demultiplexed and multiplexed passing through the 2x2 optical switches (S8 in the figure). Finally the multiplexed signal at the output of the AWG passes-through the last OMS protection (PS4) and leaves the R-OADM by the port 1. The total insertion losses inserted by an add or drop is around 14,96db, and 36,2db for and add/drop with protection.

6. R-OADM Controller

The control of the R-OADM is performed by a software module running in the OCC. This module offers an interface to the controllers (GMPLS RSVP-TE for signalling, GMPLS OSPF-TE for routing, Link Resource manager, SNMP for management, etc) of the control plane . This interface is mainly used by the GMPLS RSVP-TE signalling controller in order to establish optical connections locally. It is a proprietary interface defined specifically for the R-OADMs but it could be easily extended to support standard interfaces. When the signaling controller requests an optical connection, the R-OADM controller is in charge of sending the commands to all the optical equipments according to

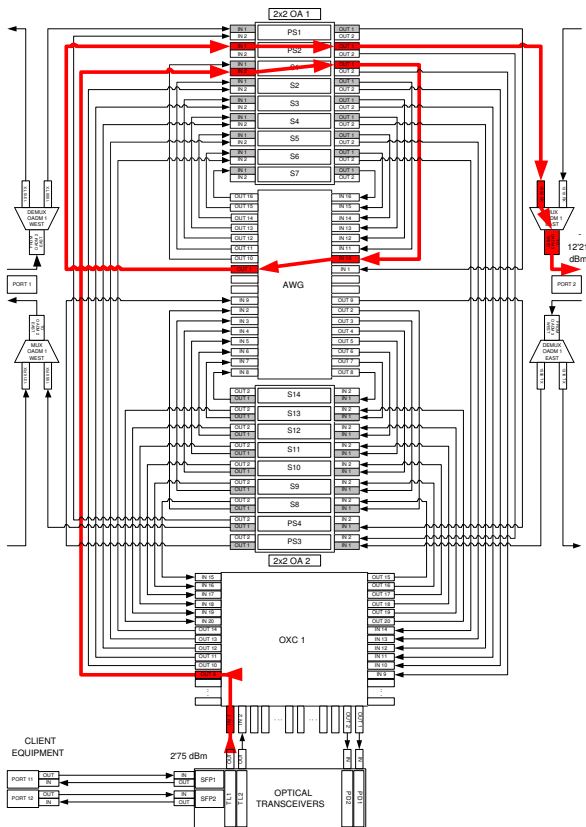

Figure 9. Example of adding of channel 30 to port 2

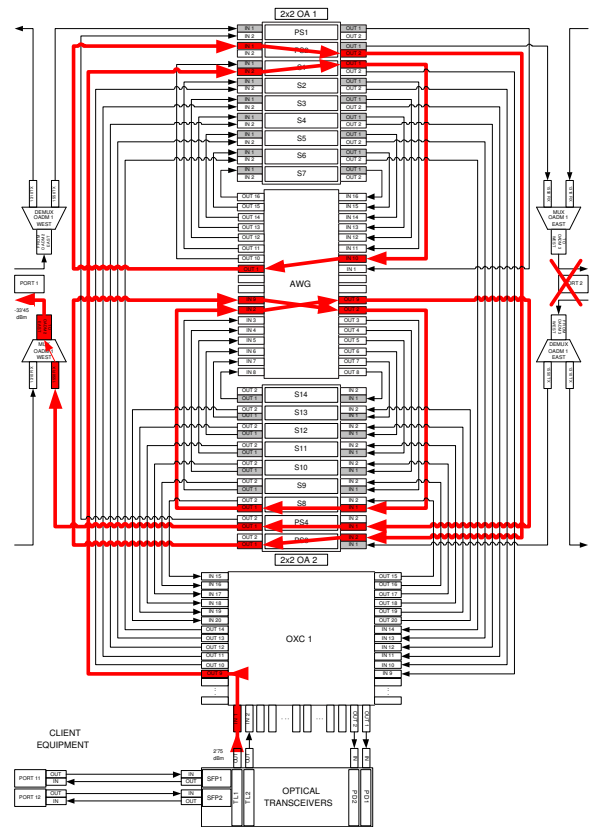

Figure 10. Example of adding of channel 30 in protection to port 1

its internal configuration tables. In a general way, it controls the 2x2 optical switches (add/drop and protection), the DWDM transceivers and the OXCs. Therefore, it offers a homogeneous interface to the control plane to manage the heterogeneous optical equipments and provides an abstraction layer to the optical layer simplifying the signalling controller processing.

To be precise, it sends a sequence of commands to the controller card of the 2x2 optical switches (OSMC) to switch on/off according to the input port, output port and channel requested by the signalling controller. It also sends the commands to the controller card of the tunable transceivers (OTSC) to turn on/off and to set the requested channel. In the same way, it sends the commands to turns on/off the fixed transceivers. Finally, it sends the commands to the TL1 controller when it is necessary to switch or configure the optical switches of the distribution stage (OXC) for adding or dropping wavelengths of any tributary client. Once the R-OADM controller has issued all the commands to the optical equipments, it waits the asynchronous responses of the optical equipments verifying its correct behavior and it sends back a unique response to the request of

the GMPLS RSVP-TE signalling controller. The R-OADM controller uses reliable TCP connections with the optical equipments to assure that there is no loss of command or response between the OCC and the optical equipments it controls. Moreover, another important function of the R-OADM controller, is that it maintains all the configuration information about the optical equipments: (1) the IP addresses of the controller cards, (2) the connections that are allowed between the input and the output ports, (3) which channels are used, (4) the state of the optical switches when a connection is requested, (5) which tunable or fixed transceivers are used, (6) which channels are set in the tunable transceivers.

7. R-OADM Monitoring

The ADRENALINE's transport plane has embedded monitoring capabilities. The transceivers provide alarms about input and output power, wavelength inaccuracy at the laser, and board temperature, among others. The 32x32 switches are enabled with asynchronous TL1 alarms about power at their input and out-

put ports. The ADRENALINE testbed integrates as well three *Optical Performance Monitors* (OPM) to obtain spectral information, namely channel and in-band *Optical Signal to Noise Ratio* (OSNR), channel and aggregate optical power, and wavelength drift. These monitors tap incoming and outgoing fibers at each node, and provide *Simple Network Management Protocol* (SNMP) notifications and alarms according to predefined thresholds. The monitors are commercial equipment by Digital Lightwave (Optical Wavelength Manager) and Proximion Fiber Optics (Wistom), capable of monitoring 8 fibers each and of scanning a full spectrum in tens of microseconds. The ADRENALINE testbed also provides digital performance monitoring information in the form of *Bit Error Rate* (BER) computation, which is done by the Broadband Tester. Last but not least, in the future, dispersion monitors will be purchased to measure pulse broadening caused by chromatic and polarization mode dispersion. All these equipment is part of the ADRENALINE's in-service performance monitoring system, described in [7]. Moreover, an Optical Time Domain Reflectometer (OTDR) is used for out-of-service fiber attenuation measurements.

By using the above-listed elements, each R-OADM has the following monitoring points: one OPM tapping the input and output fibers of the node, which measures power, wavelength drift and OSNR of the channels going through the add/drop stage; autonomous alarms of input and output channel power at the distribution stage; asynchronous alarms of the transceivers; and BER computation by the client equipment. This is illustrated in Figure 11, along with the protocols used for monitoring. It is important to note that since the ADRENALINE scenario of traffic demands and connection provisioning is highly dynamic, and the capabilities of remote update of the monitor's thresholds are very limited with respect to the dynamicity of the network, the ADRENALINE testbed considers a service scenario in which the edge elements (e.g. routers of a service provider) are responsible for aggregating traffic flows of a given type so that a given tributary of an edge element corresponds to an ADRENALINE lambda service class. Then, ADRENALINE allocates sets of channels to each tributary. For example, an ingress edge router would aggregate traffic flows a and b so that ADRENALINE can allocate up to N WDM channels in the range $[\lambda_{a_1}, \lambda_{a_N}]$ to the traffic flow a and up to M channels in the range $[\lambda_{b_1}, \lambda_{b_M}]$ to the traffic flow b . Then, the lambda services are accessed through an interface located at the ingress OADM, where the end points of the transparent lightpath are accessible. This way QoS policies, applied by the control and management planes, are directly related to tributaries and wavelength allocation.

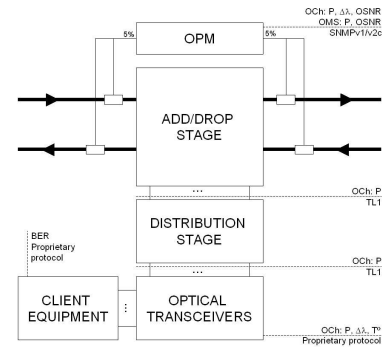

Figure 11. R-OADM monitoring points

8. Conclusions

This paper has presented the metropolitan all-optical ring network implemented in the ADRENALINE testbed based on tuneable AWG-based R-OADMs. The architecture, control and monitoring of the implemented R-OADMs has been explained in detail, demonstrating the feasibility of the new advances in optical technology for building reliable all-optical transport networks without any electrical conversion, allowing the transport of high-bandwidth end-to-end optical connections independent to the format or bit-rate of the client traffic.

References

- [1] T. Denton, F. Menard, and D. Isenberg, "Netheads versus bellheads: Research into emerging policies in the development and deployment of internet protocols," in *T.M. Denton Consultants*, May 2004.
- [2] D. Benajmin, R. Trudel, S. Shew, and k. Kus, "Optical services over the intelligent optical network," in *IEEE Communications Magazine*, September 2001, p. 73.
- [3] B. Mukherjee, *Optical Communication Networks*, McGraw-Hill, Ed., 1997.
- [4] R. Munoz, C. Pinart, R. Martinez, J. Sorribes, M. Maier, A. Amrani, and G. Junyent, "The adrenaline test bed: Integrating gmpls, xml and snmp in transparent dwdm networks," in *IEEE Communications Magazine*, vol. 43, no. 8, August 2005, pp. 40–48.
- [5] R. Munoz, R. Martinez, J. Sorribes, and G. Junyent, "Experimental gmpls-based provisioning for future all-optical dpring-based man," in *IEEE/OSA Journal of Lightwave Technologies*, vol. 23, no. 10, October 2005, pp. 3034–3045.
- [6] C. Pinart and G. Junyent, "On managing optical services in future control plane enabled ip/wdm networks," in *IEEE/OSA Journal of Lightwave Technologies*, vol. 23, no. 10, October 2005, pp. 2868–2876.
- [7] C. Pinart and et al., "Design and experimental implementation of a hybrid optical performance monitoring system for in-service sla guarantee," in *Proc. 9th IFIP/IEEE International Symposium on Integrated Network Management*, May 2005.